

SALES DRAWING SALES DRAWING

SALES DRAWING SALES DRAWING

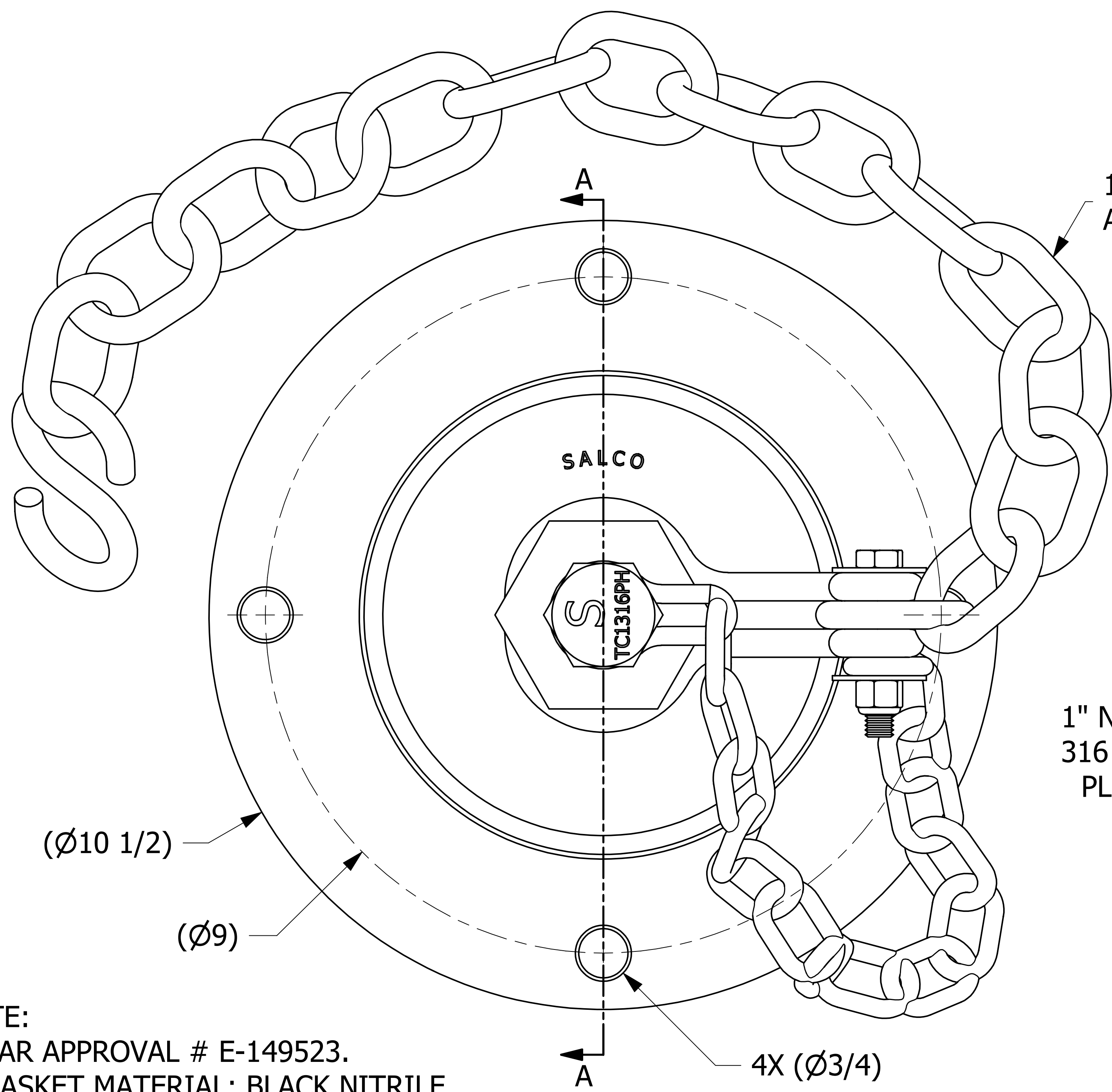

15 LINKS OF 3/8" 18-8 SS CHAIN  
APPROXIMATE LENGTH IS 21"

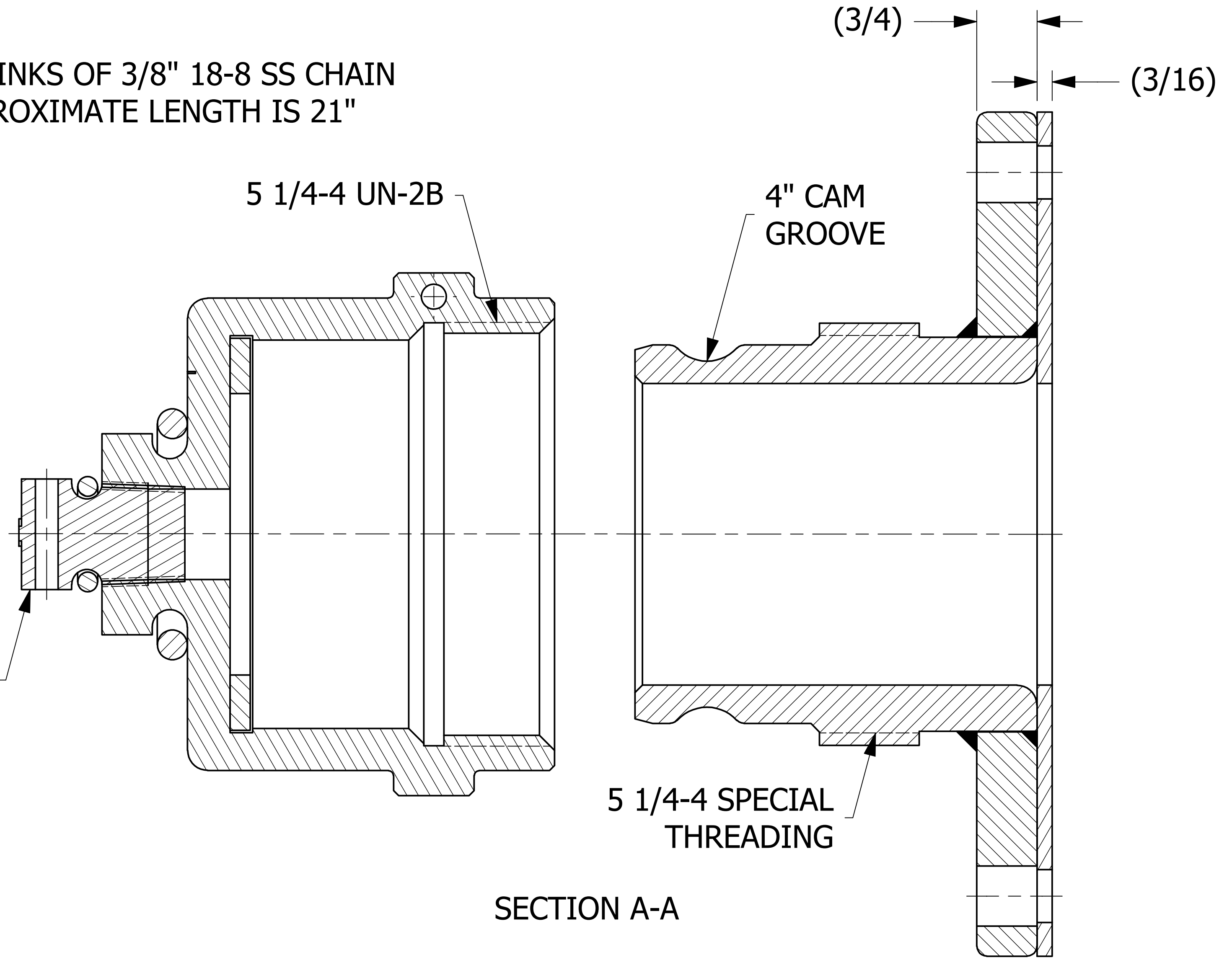

SECTION A-A

- NOTE:
1. AAR APPROVAL # E-149523.
  2. GASKET MATERIAL: BLACK NITRILE.
  2. FITS 4" JAMESBURY BALL VALVE (9.00"B.C.)
  4. APPROXIMATE HEIGHT: 8".
  5. THIS ASSEMBLY IS AAR AND DOT APPROVED.
  6. QUICK CONNECT MEETS A-A-59326D.
  7. CAP MATERIAL: 416 SS.
  8. FLANGE MATERIAL: 316 SS.
  9. 5 1/4-4 UN - 2B THREADS CONFORM TO FIGURE E18 OF THE AAR TANK CAR MANUAL.

C	RJP	1-27-17	E-149523 WAS E-049013, UPDATED GEOMETRY OF TE4S416DC1A
B	WEB	2-19-13	PART NUMBER WAS TE4S416SWF1A
A	WEB	2-18-13	RELEASED FOR PRODUCTION
REV	BY	DATE	DESCRIPTION

UNLESS OTHERWISE SPECIFIED DIMENSIONAL TOLERANCES FRACTIONAL: ±1/16 X.XX: ±.03 X.XXX: ±.015 ANGULAR: ±1° DEBURR ALL SHARP EDGES. ALL MACHINED SURFACES TO HAVE A 125 RMS FINISH UNLESS NOTED OTHERWISE. THIRD ANGLE PROJECTION	DRAWN BY:	WEB
	CHECKED BY:	CHL
	PROTOTYPE BY:	WEB
	PROTOTYPE DATE:	2/15/2013
	APPROVED FOR PRODUCTION BY:	VD
	PRODUCTION DATE:	2/18/2013

**SALCO PRODUCTS, INC.**

PART NAME: **UNLOADING ADAPTER 4" FLANGED**

MATERIAL: **SEE NOTES**

PROJECT #: **130214FR** SHEET #: **1 OF 1** SCALE: **3:4**

DRAWING #: **D35399** PART #: **TE4S416SFW1A**

THIS PRINT, PROPERTY OF SALCO PRODUCTS INC. CONTAINS PROPRIETARY INFORMATION AND MUST NOT BE COPIED, REPRODUCED, OR USED DETRIMENTALLY TO OUR INTEREST.